

INSTALLATION INSTRUCTIONS

Accessory
SADDLE BAG PIPE
(P/N 08P52-MZ0-100)

Application
GL1500CT

Publications No.

Issue Date
March, 1996

Accessory Weight : 4.1kg (9.0 lbs)

READ THESE INSTRUCTIONS CAREFULLY.

1 PARTS LIST

Fig. 1

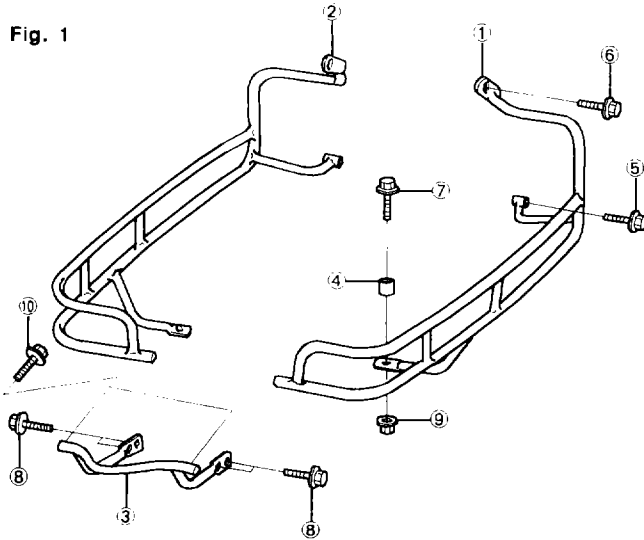

No.	Description	Q'ty	Part No.
①	Right saddle bag pipe	1	08P52-MZ0-100-01
②	Left saddle bag pipe	1	08P52-MZ0-100-02
③	Sub saddle bag pipe	1	08P52-MZ0-100-03
④	Collar	2	30507-441-000
⑤	8×45mm Flange bolt	2	90158-MB1-000
⑥	8×14mm Flange bolt	2	95701-08014-00
⑦	6×45mm Flange bolt	2	08P52-MZ0-100-05
⑧	6×18mm Flange bolt	4	95701-06018-00
⑨	6mm Flange nut	2	94050-6000
⑩	6×12mm Flange bolt	2	95701-06012-00

2 TOOLS REQUIRED

- 14mm T-handle wrench
- 12mm T-handle wrench
- 10mm T-handle wrench
- 10mm Combination wrench
- 8mm Combination wrench
- 10mm Open-end wrench

3 PRECAUTIONS

- To prevent scalding, do not install the saddle bag pipes when the engine and exhaust pipes are hot.
- Be sure to tighten all bolts, nuts and other fasteners to the specified torques.
- Loose or missing bolts and nuts can impair motorcycle's stability and performance, resulting in serious accident or injury.
- Standard torques

Item	N · m	kgf-m	lb · ft
8mm Flange bolt	26	2.7	20
6mm Flange bolt and nut	12	1.2	9

4 INSTALLATION

1. Remove the seat.

Fig. 2

