

INSTALLATION INSTRUCTIONS

Accessory
REAR CARRIER
P/N 08L42-MZ0-100

Application
GL1500C

Publications No.
MII7251 (9603)

Issue Date
March, 1996

Accessory Weight : 1.9 lbs (0.86kg)

READ THESE INSTRUCTIONS CAREFULLY.

1 PARTS LIST

Fig. 1

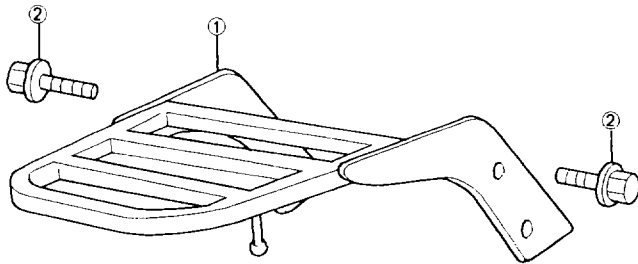

No.	Description	Q'ty	Part No.
①	Rear carrier	1	08L42-MZ0-100-01
②	6×16mm SH Flange bolt	4	96001-06016-02

2 TOOL REQUIRED

- 8mm T-handle box wrench

TORQUE CHART

Item	N · m	kgf-m	ft-lbs
6mm SH Flange bolt	9	0.9	6.5

3 INSTALLATION

1. Remove the four small head 6mm bolts attaching the backrest.
2. Install the rear carrier using four 6×16mm small head bolt. Torque the bolts.

Fig. 2

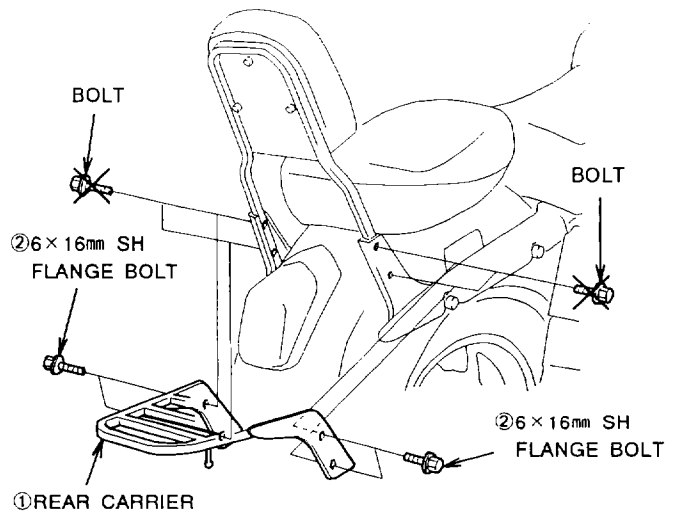

4 USE AND CARE

- Cargo weight alone should not exceed :

Maximum Allowable Cargo Weight	6.6 lbs (3kg)
--------------------------------	---------------

- Addition of accessories and cargo can reduce a motorcycle's stability, performance and safe operating speed. Obey local laws and regulations.
- Do not move the motorcycle by holding on the rear carrier.

READ THE OWNER'S MANUAL CAREFULLY.
The Owner's Manual has additional safety and operational information.