

**INSTALLATION INSTRUCTIONS**

Accessory  
**EXHAUST PIPE FINISHER**  
 P/N 08F53-MZ0-100

Application  
**GL1500C**

Publications No.  
 MII7254 (9603)

Issue Date  
 March, 1996

Accessory Weight : 5.1 lbs (2.3kg)

**READ THESE INSTRUCTIONS CAREFULLY.**

**1 PARTS LIST**

Fig. 1

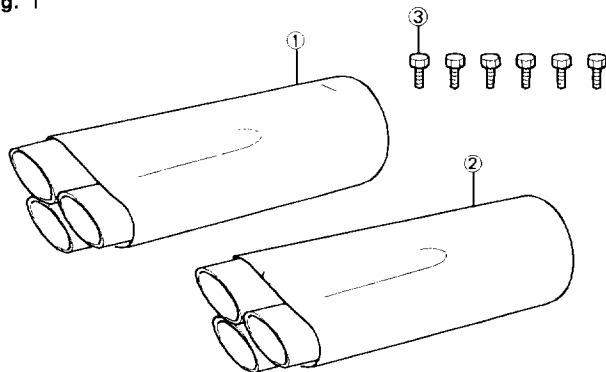

No.	Description	Q'ty	Part No.
①	Right exhaust pipe finisher	1	08F53-MZ0-100-01
②	Left exhaust pipe finisher	1	08F53-MZ0-100-02
③	6×12mm Bolt	6	08F53-MZ0-100-03

**2 TOOL REQUIRED**

- 8mm Combination wrench
- 10mm Combination wrench

**3 RECAUTIONS**

- To prevent scalding, do not install the finishers when the engine and exhaust system are hot.

**TORQUE CHART**

Item	N · m	kgf-m	ft-lbs
6mm Flange bolt	12	1.2	9

**4 INSTALLATION**

1. Remove 3bolts, lockwashers and washers and one of the original finisher. Keep the lockwashers (3) and washers (3). Do this for both side.
2. Install one new finisher using 3 6×12mm bolts, 3 lockwashers and 3 washers. Do this for both side. Torque all 6 bolts.

Fig. 2

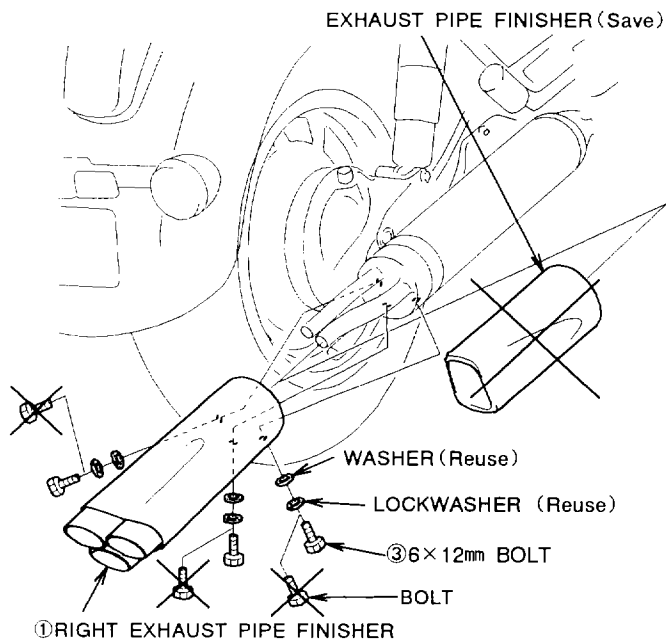

**READ THE OWNER'S MANUAL CAREFULLY.**  
 The Owner's Manual has additional safety and operational information.